

Application Note

OVERVIEW

The SM8144 has an EL ON/OFF control pin, ENA (ON when HIGH, and OFF when LOW). The inductor drive and EL output frequencies are derived from a single built-in oscillator (OSC), however, the frequencies cannot be changed independently of one another.

DESCRIPTION

The SM8144 comprises an oscillator, booster, and high voltage switching circuit functional blocks.

Block Diagram

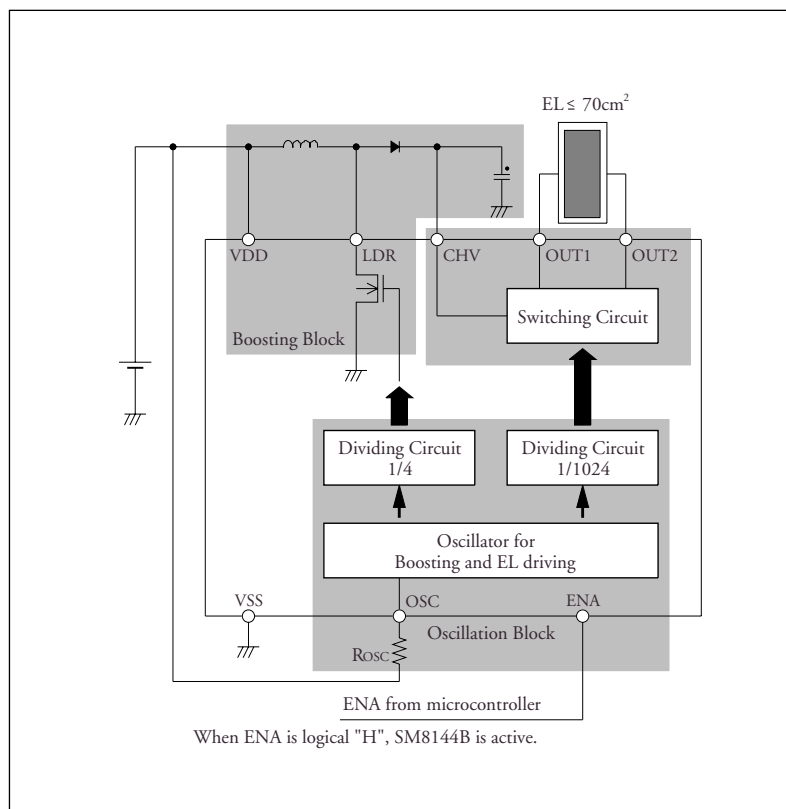

Figure 1. SM8144 Block Diagram

Oscillator

The built-in oscillator circuits require only the connection of an external resistor to form RC oscillator circuits. Changing the value of the external resistor causes the frequency of the oscillator to change. When the resistance is increased, the frequency of oscillation decreases and, conversely, when the resistance is decreased, the frequency of oscillation increases.

The frequency of the oscillator is divided to form two frequency signals, f_{LDR} and f_{OUT} . The f_{LDR} frequency is derived from a 1/4 divider, and f_{OUT} is derived from a 1/1024 divider. The relationship between resistance values and f_{LDR} and f_{OUT} is shown in figures 2 to 5. Note that the measurements shown in the characteristics diagrams were measured using an NPC standard PCB, and that capacitance due to different wiring patterns may have a small effect on these values.

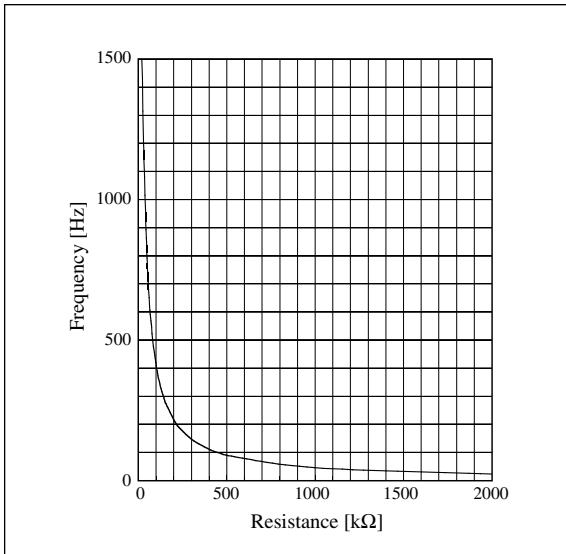

Figure 2. $R_{OSC} - f_{OUT}$

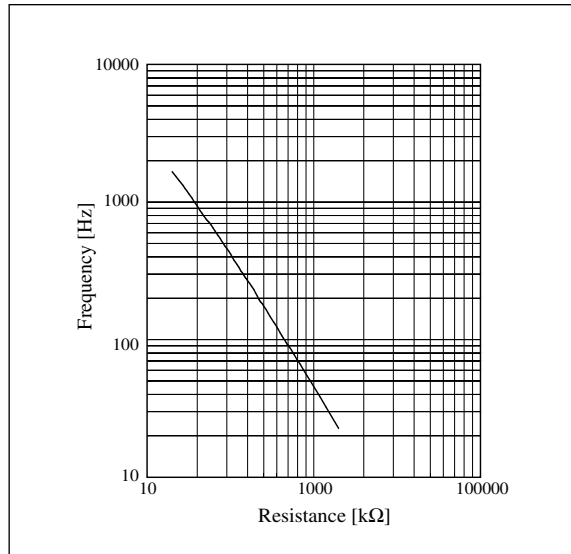

Figure 3. $R_{OSC} - f_{OUT} (LOG)$

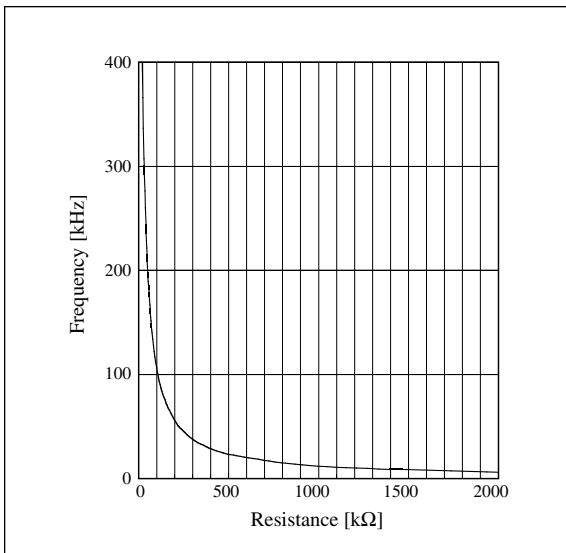

Figure 4. $R_{OSC} - f_{LDR}$

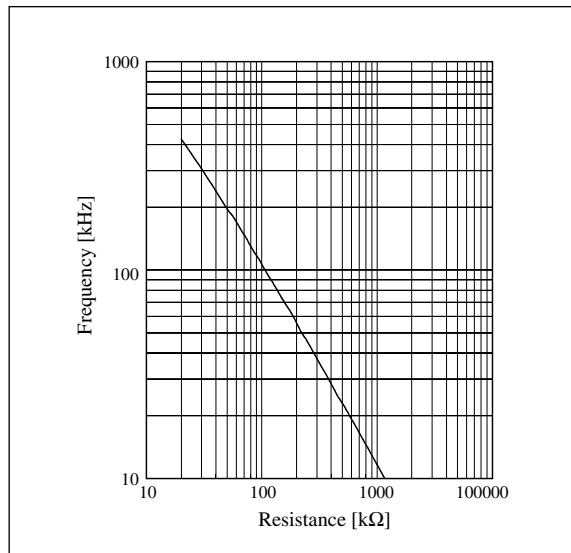

Figure 5. $R_{OSC} - f_{LDR} (LOG)$

Booster

The oscillator frequency is divided by 4 to form the inductor drive clock (f_{LDR}), which is used to switch the inductor drive transistor to boost the voltage from battery-level voltages up to a maximum of 100V DC. The switching duty ratio is fixed with a cycle of 75% ON and 25% OFF. When the inductor drive transistor is ON, the inductor current flows through the inductor drive transistor, as shown in the following figure.

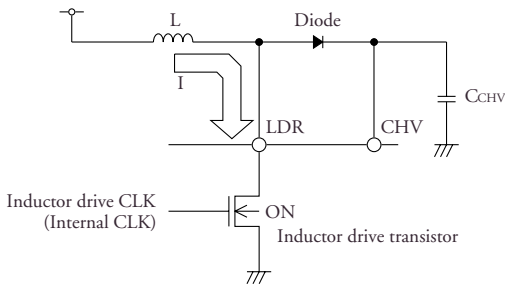

Figure 6. Boost circuit (transistor ON)

The current I [A] is a function of the coil inductance L [H], the voltage across the inductor V [V], and the inductor drive transistor ON time t_{ON} [sec], given by:

$$I = \left(\frac{V}{L}\right) \times t_{ON} \text{ [A]}$$

and the inductor stores this energy as magnetic energy. When the inductor drive transistor is OFF, the current in the inductor drive transistor necessarily reduces to zero. However, the inductor current naturally continues to flow and is redirected through the diode and capacitor, which stores the energy as electric energy. At this point, a counter emf appears on pin LDR.

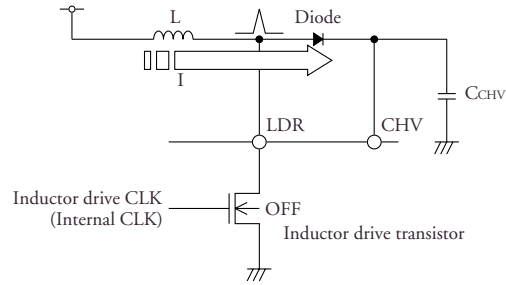

Figure 7. Boost circuit (transistor OFF)

This operation repeats as the transistor is switched ON and OFF, thereby boosting the voltage on pin CHV to stabilize the power consumption in the EL output stage. Note that the rating for the voltage on CHV is 100V maximum, so care should be taken not to exceed this value.

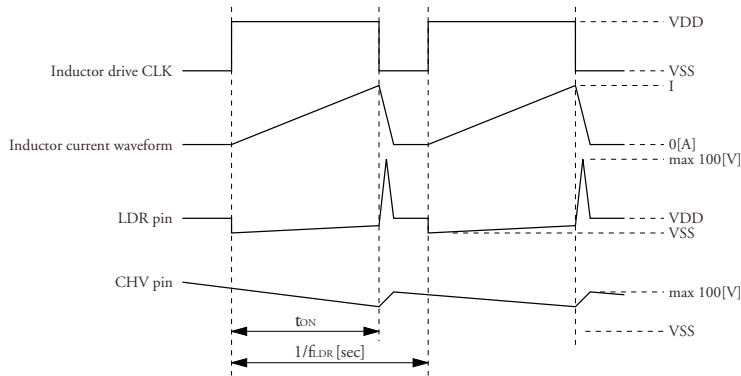

Figure 8. Boost circuit timing

The inductor drive clock duty ratio is 75%, and therefore the voltage is applied to the inductor for time t_{ON} , given by:

$$t_{ON} = 0.75 \times \frac{1}{f_{LDR}} \text{ [sec]}$$

and the energy stored in the inductor (E) is given by:

$$E = \frac{1}{2} \times f_{LDR} \times L \times I^2 \approx 0.28 \times \frac{V^2}{f_{LDR} \times L}$$

For example, if the frequency is halved, then the ON time for which current flows through the inductor is doubled, the current through the inductor is also doubled, and the energy stored in the inductance coil is also doubled. Also, if the coil inductance is halved, then the current and energy are doubled. If the voltage is doubled, then the current is doubled and the energy is quadrupled.

The booster energy can be adjusted by controlling the coil inductance drive frequency, the inductance of the coil, and the voltage across the inductor to meet the desired application.

Output Stage

The high voltage created in the booster stage is passed to the output stage and two signals OUT1 and OUT2 from a bridge circuit are output at a frequency

f_{OUT} generated by the oscillator. The output frequency can be adjusted using the external resistance values of R_{OSC} .

Output Waveform

Ideally, the SM8144 output waveform for efficient EL illumination is a rectangular-like drive waveform as shown in figure 10. If the EL element oscillates in a particular application, then the output waveform can be slightly smoothed by adjusting an output

resistor R_{OUT} shown in figure 9. The output waveform is smoother for higher values of resistance for R_{OUT} , which will help control noise but at the expense of higher loss.

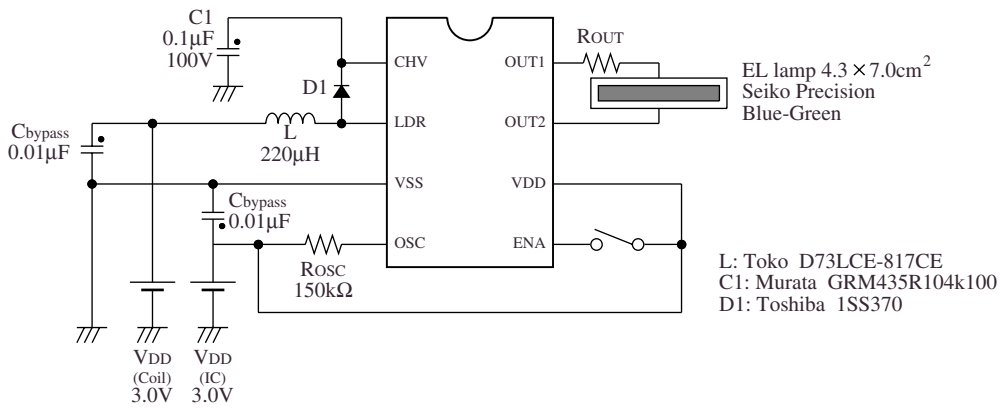

Figure 9. Output waveform adjustment circuit

The effect of R_{OUT} for values of 0, 5.1kΩ, 10kΩ, and 20kΩ are shown in the following table and figures.

R_{OUT} [kΩ]	R_{OSC} [kΩ]	Current consumption [mA]	f_{OUT} [Hz]	V_{OUT} [Vp-p]	Brightness [cd/m ²]	Waveform
0.0	180	56.4	245	192	27.2	Figure 10
5.1	180	56.8	245	182	22.3	Figure 11
10.0	180	57.2	245	170	19.2	Figure 12
20.0	180	57.1	245	164	16.3	Figure 13

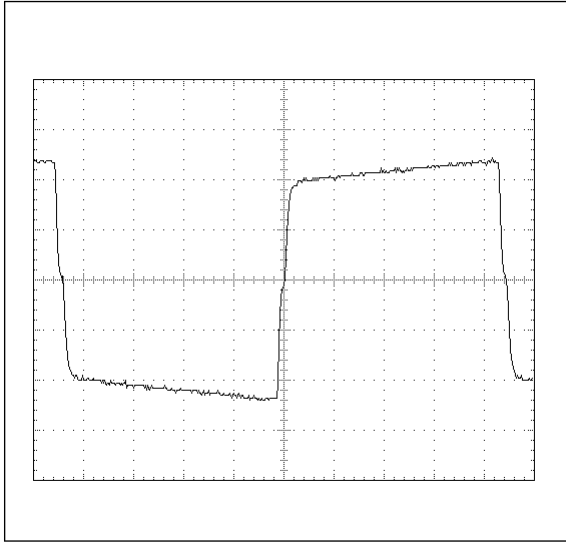

Figure 10. $R_{OUT} = 0$

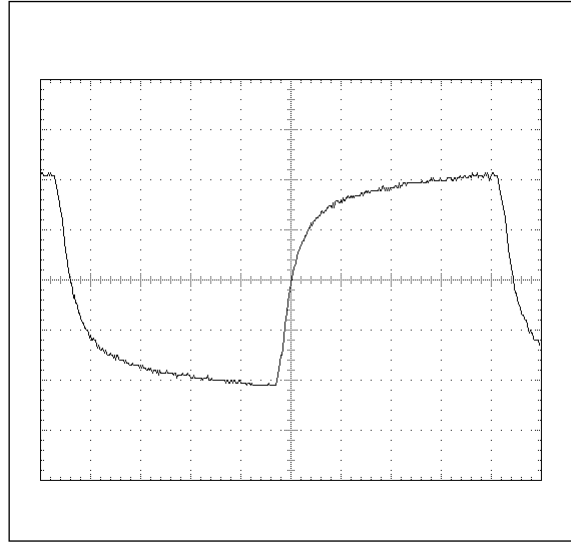

Figure 12. $R_{OUT} = 10k\Omega$

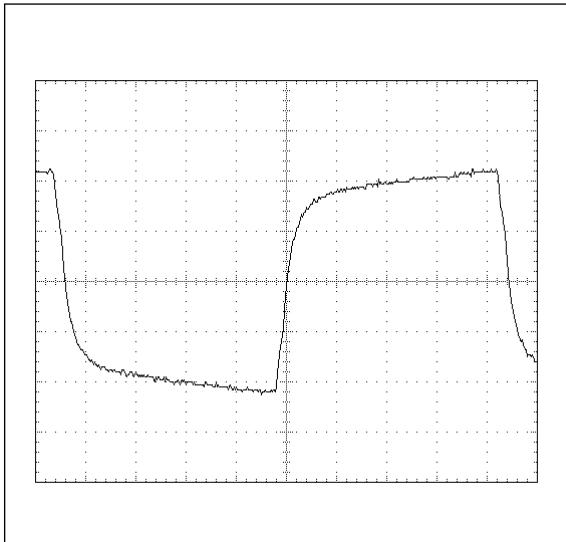

Figure 11. $R_{OUT} = 5.1k\Omega$

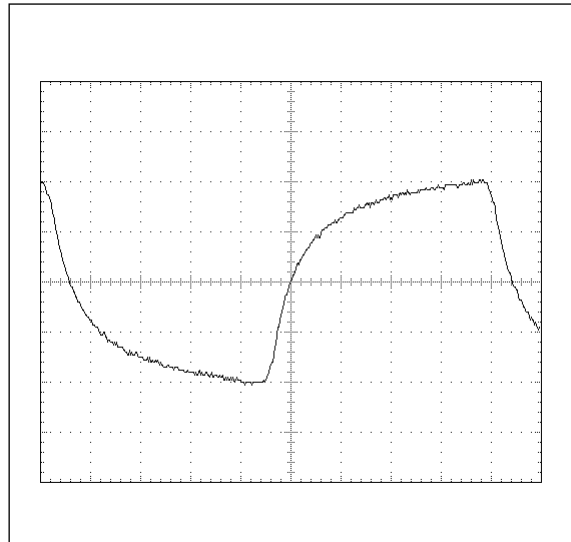

Figure 13. $R_{OUT} = 20k\Omega$

TYPICAL APPLICATION CIRCUIT

V_{DD}: 2.4 [V], EL size: 15 [cm²], inductor: Toko D73LCE-817CE

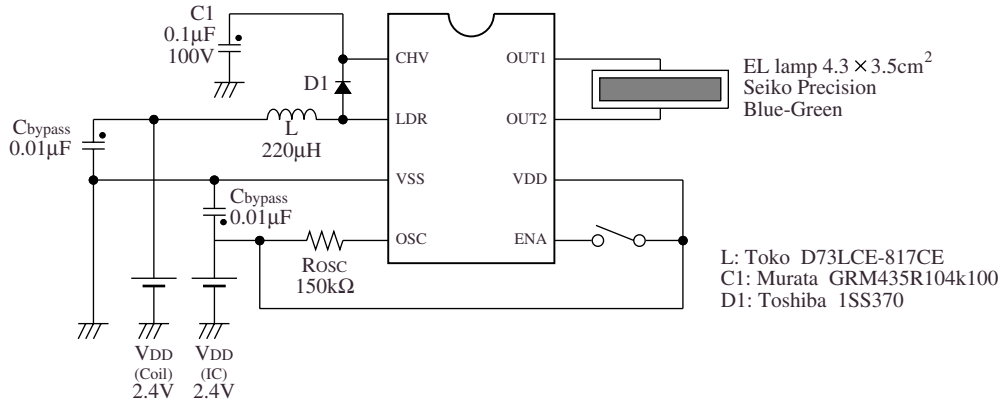

Figure 14. Application circuit

The inductance, R_{OSC} can all be adjusted to control the brightness and current consumption required in a particular application, as summarized in the following table.

EL size [cm ²]	Inductance [µH]	R _{osc} [kΩ]	Current consumption [mA]	f _{OUT} [Hz]	V _{OUT} [V _{p-p}]	Brightness [cd/m ²]
15.0	470	240	26.1	184	186	23.0
15.0	470	150	17.0	289	134	16.5
15.0	330	180	32.0	244	176	26.5
15.0	330	100	19.9	419	120	16.9
15.0	220	150	38.0	291	174	28.9
15.0	220	75	23.1	543	116	17.2

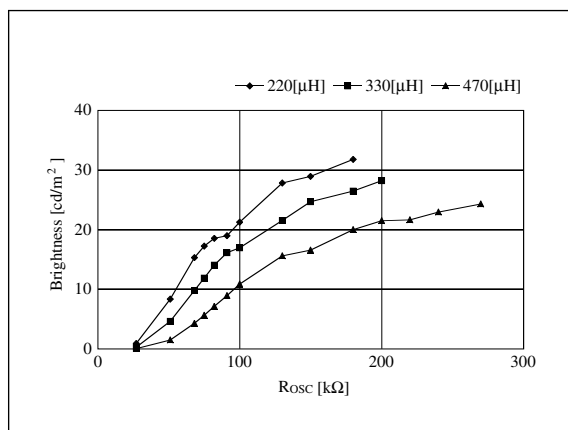

Figure 15. R_{OSC} – Brightness

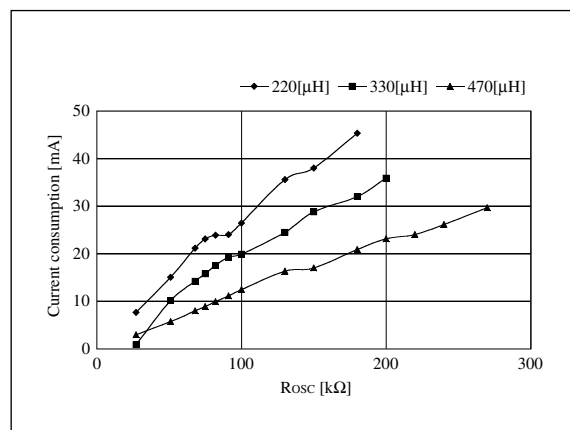

Figure 16. R_{OSC} – Current consumption

V_{DD}: 2.4 [V], EL size: 15 [cm²], inductor: Murata LQH4N

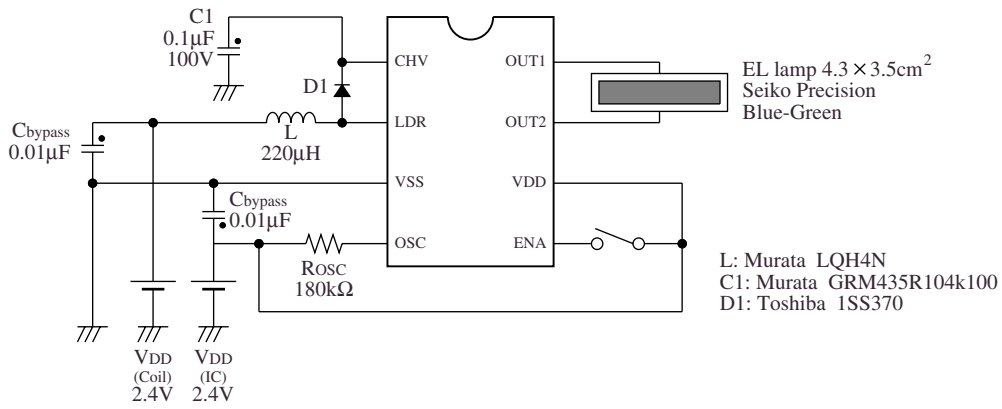

Figure 17. Application circuit

EL size [cm ²]	Inductance [µH]	R _{OSC} [kΩ]	Current consumption [mA]	f _{OUT} [Hz]	V _{OUT} [Vp-p]	Brightness [cd/m ²]
15.0	470	270	26.3	164	180	19.5
15.0	470	150	16.1	290	124	13.9
15.0	330	220	32.6	198	184	23.3
15.0	330	130	21.3	330	132	17.4
15.0	220	180	40.4	241	184	27.2
15.0	220	100	23.5	419	124	18.0

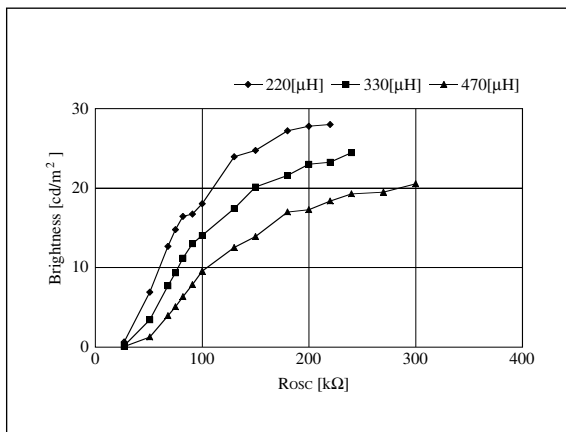

Figure 18. R_{OSC} – Brightness

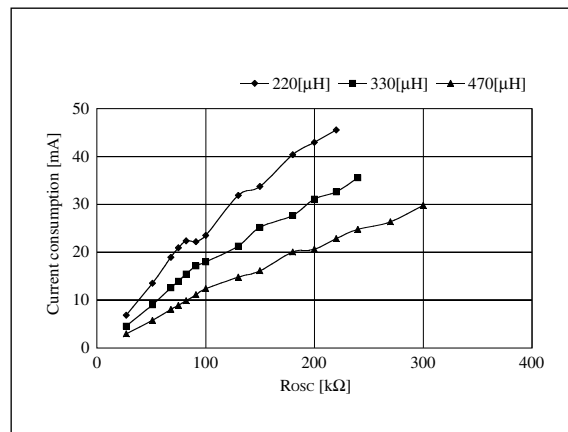

Figure 19. R_{OSC} – Current consumption

V_{DD}: 2.4 [V], EL size: 30 [cm²], inductor: Toko D73LCE-817CE

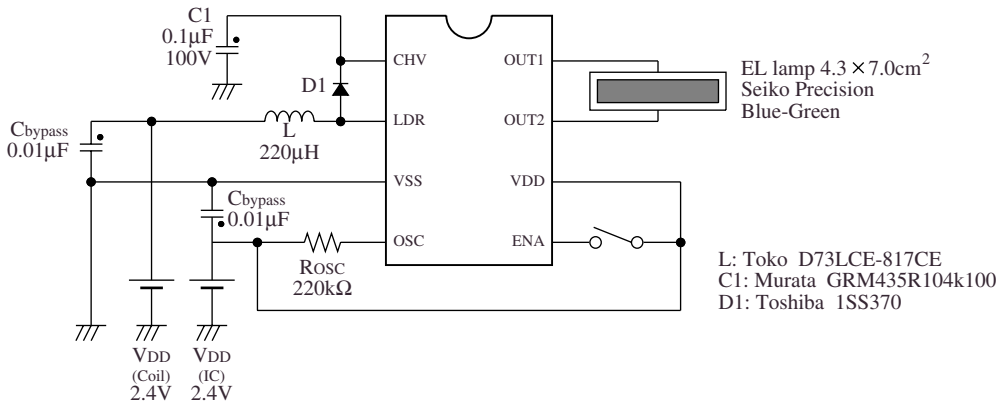

Figure 20. Application circuit

EL size [cm ²]	Inductance [µH]	R _{OSC} [kΩ]	Current consumption [mA]	f _{OUT} [Hz]	V _{OUT} [Vp-p]	Brightness [cd/m ²]
30.1	470	300	33.2	148	172	14.9
30.1	470	200	22.5	219	130	10.9
30.1	330	270	46.6	164	184	18.2
30.1	330	200	35.5	219	150	15.2
30.1	220	220	53.9	197	176	19.6
30.1	220	150	40.2	290	137	16.0

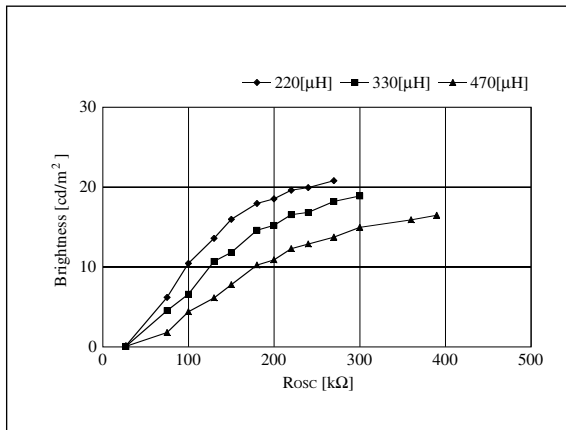

Figure 21. R_{OSC} – Brightness

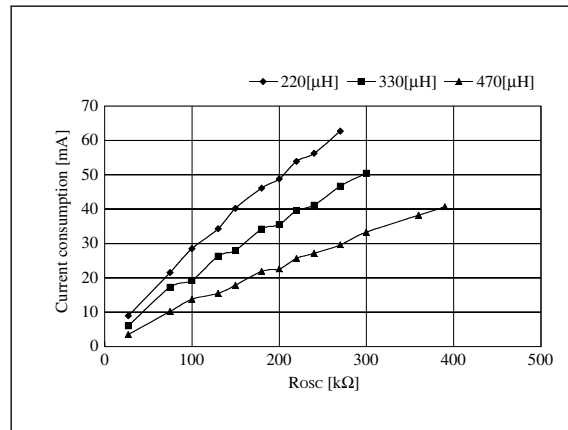

Figure 22. R_{OSC} – Current consumption

V_{DD} : 2.4 [V], EL size: 30 [cm²], inductor: Murata LQH4N

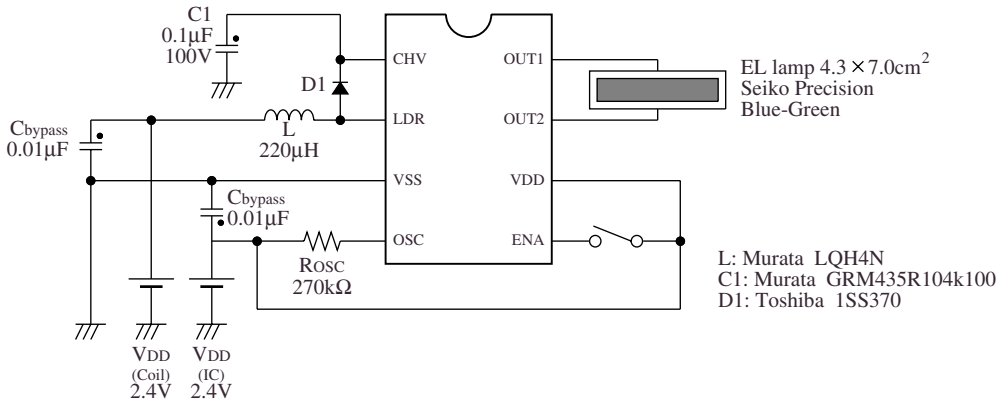

Figure 23. Application circuit

EL size [cm ²]	Inductance [µH]	R _{OSC} [kΩ]	Current consumption [mA]	f _{OUT} [Hz]	V _{OUT} [Vp-p]	Brightness [cd/m ²]
30.1	470	360	33.5	124	166	12.2
30.1	470	200	21.2	219	116	9.0
30.1	330	300	42.5	148	172	15.1
30.1	330	150	24.6	289	110	10.0
30.1	220	270	55.1	164	178	17.4
30.1	220	150	35.5	290	126	13.5

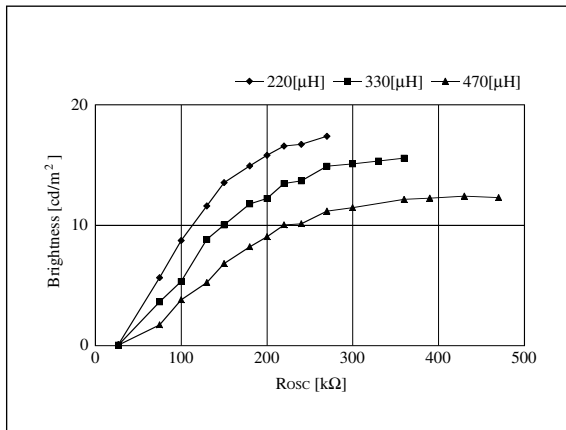

Figure 24. R_{OSC} – Brightness

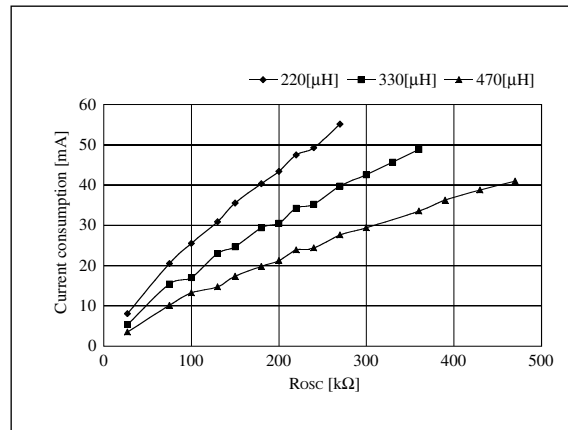

Figure 25. R_{OSC} – Current consumption

V_{DD}: 3.0 [V], EL size: 30 [cm²], inductor: Toko D73LCE-817CE

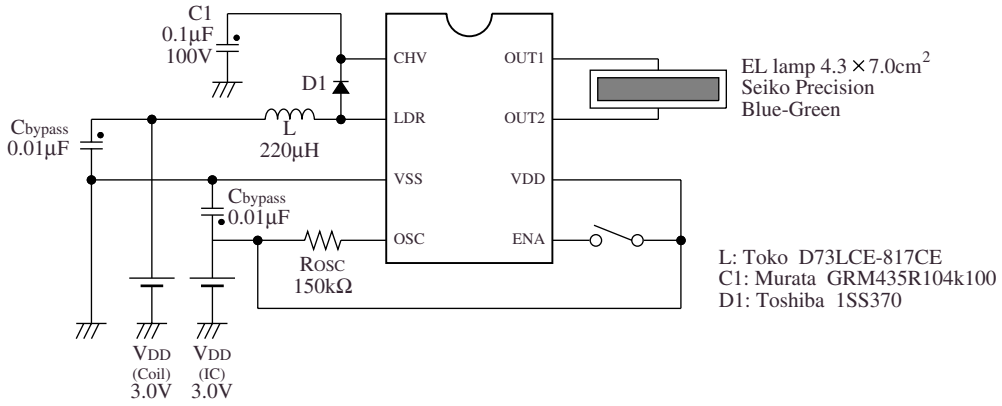

Figure 26. Application circuit

EL size [cm ²]	Inductance [µH]	R _{OSC} [kΩ]	Current consumption [mA]	f _{OUT} [Hz]	V _{OUT} [Vp-p]	Brightness [cd/m ²]
30.1	470	240	33.5	186	178	20.1
30.1	470	130	19.2	334	111	11.4
30.1	330	180	42.4	245	174	23.4
30.1	330	91	22.5	465	104	11.1
30.1	220	150	50.0	294	170	25.9
30.1	220	68	27.3	601	101	12.0

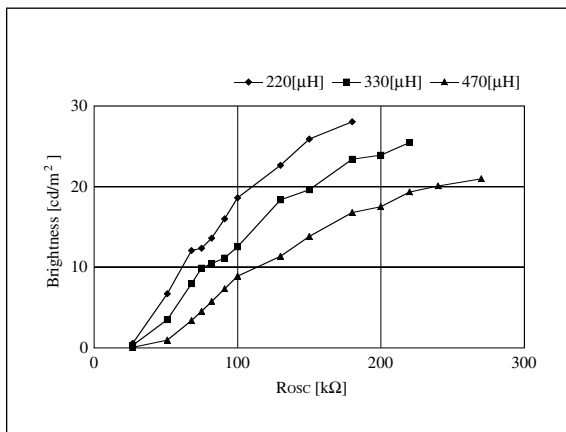

Figure 27. R_{OSC} – Brightness

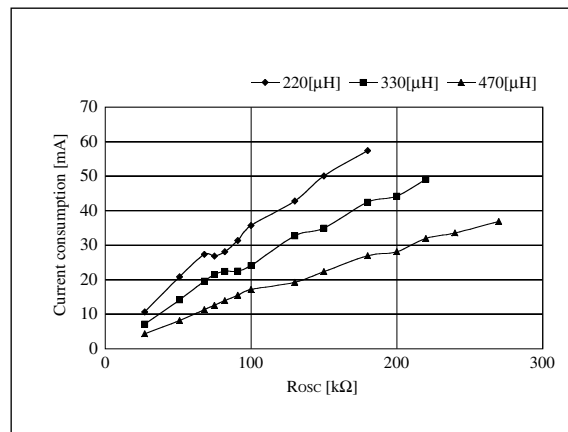

Figure 28. R_{OSC} – Current consumption

V_{DD}: 3.0 [V], EL size: 30 [cm²], inductor: Panasonic ELL6SH

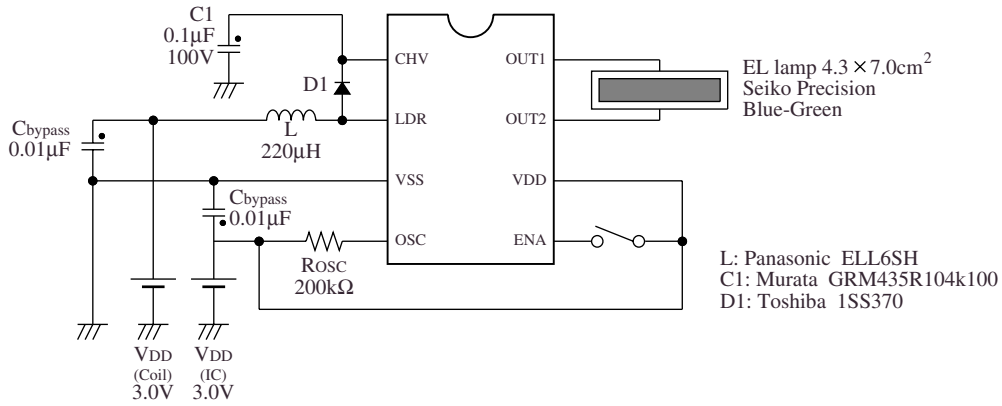

Figure 29. Application circuit

EL size [cm ²]	Inductance [µH]	R _{OSC} [kΩ]	Current consumption [mA]	f _{OUT} [Hz]	V _{OUT} [Vp-p]	Brightness [cd/m ²]
30.1	470	270	36.2	166	188	19.9
30.1	470	130	18.9	334	108	10.3
30.1	330	240	38.1	186	184	20.7
30.1	330	130	23.2	334	117	12.6
30.1	220	200	50.9	221	188	24.4
30.1	220	82	23.9	510	99.2	10.3

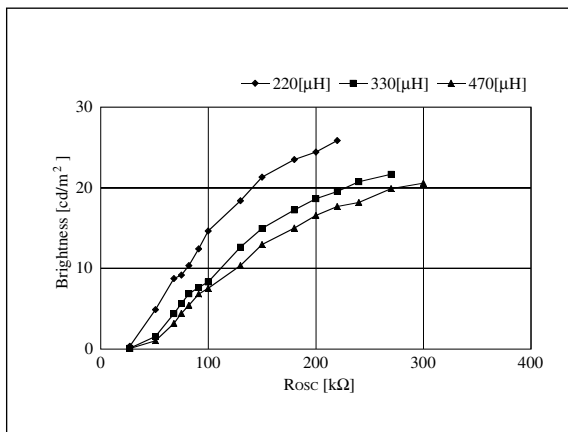

Figure 30. R_{OSC} – Brightness

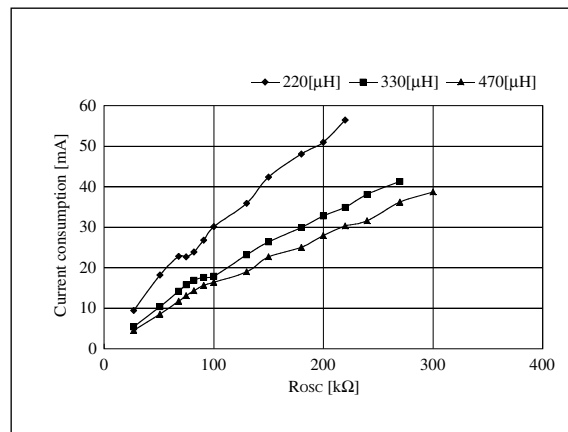

Figure 31. R_{OSC} – Current consumption

V_{DD}: 3.0 [V], EL size: 50 [cm²], inductor: Toko D73LCE-817CE

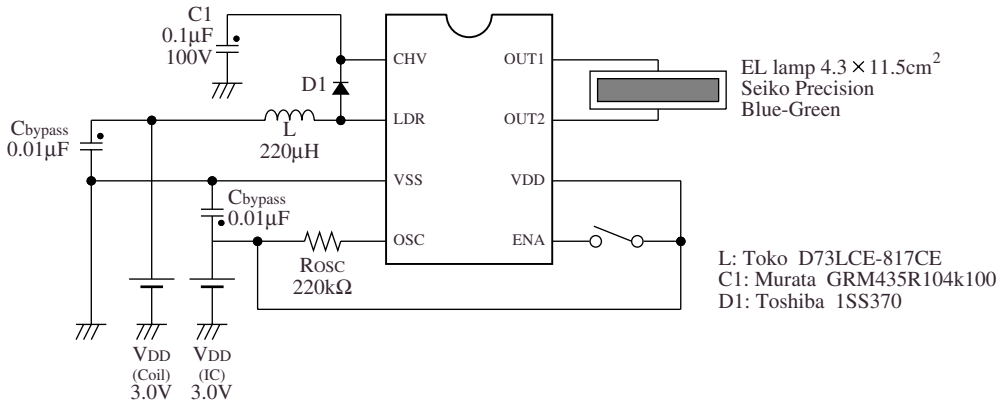

Figure 32. Application circuit

EL size [cm ²]	Inductance [µH]	R _{OSC} [kΩ]	Current consumption [mA]	f _{OUT} [Hz]	V _{OUT} [Vp-p]	Brightness [cd/m ²]
49.5	470	300	41.1	149	176	13.7
49.5	470	200	28.8	222	130	9.9
49.5	330	240	52.3	186	176	16.1
49.5	330	130	32.9	334	116	9.8
49.5	220	220	66.9	199	188	19.1
49.5	220	130	43.7	335	124	12.7

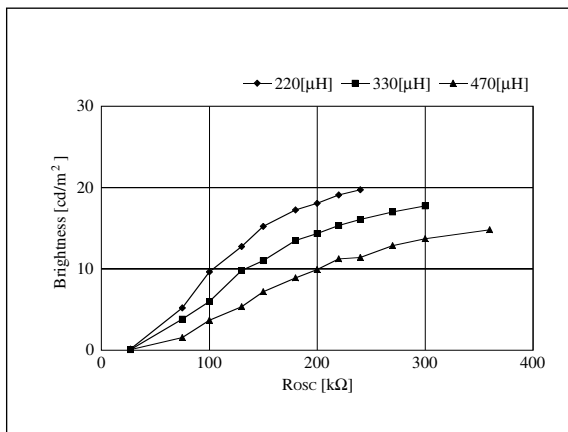

Figure 33. R_{OSC} – Brightness

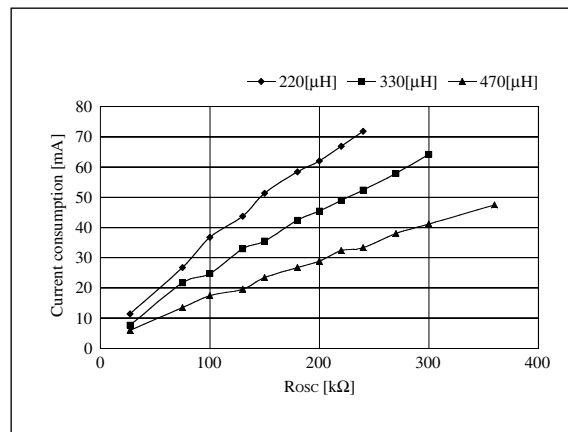

Figure 34. R_{OSC} – Current consumption

V_{DD} : 3.0 [V], EL size: 50 [cm²], inductor: Panasonic ELL6SH

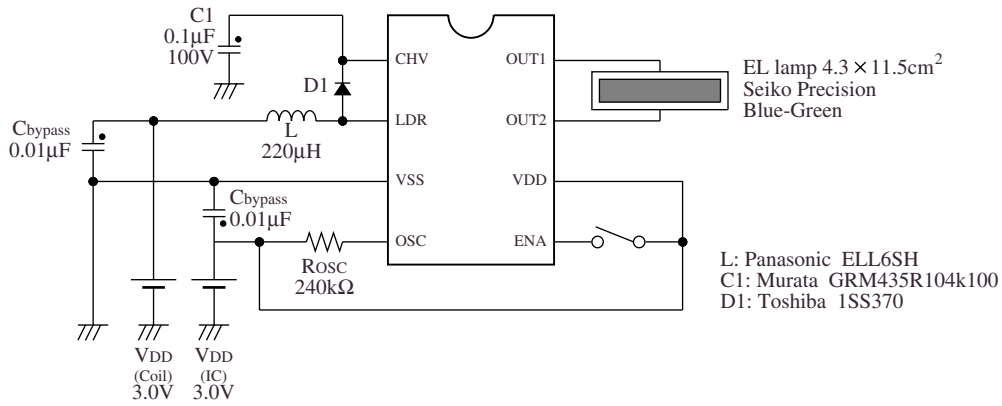

Figure 35. Application circuit

EL size [cm ²]	Inductance [µH]	R _{OSC} [kΩ]	Current consumption [mA]	f _{OUT} [Hz]	V _{OUT} [Vp-p]	Brightness [cd/m ²]
49.5	470	300	39.5	149	172	12.8
49.5	470	220	30.2	200	135	9.9
49.5	330	300	46.5	298	182	14.3
49.5	330	180	30.9	245	126	9.7
49.5	220	240	59.8	186	180	16.9
49.5	220	130	36.7	334	118	10.2

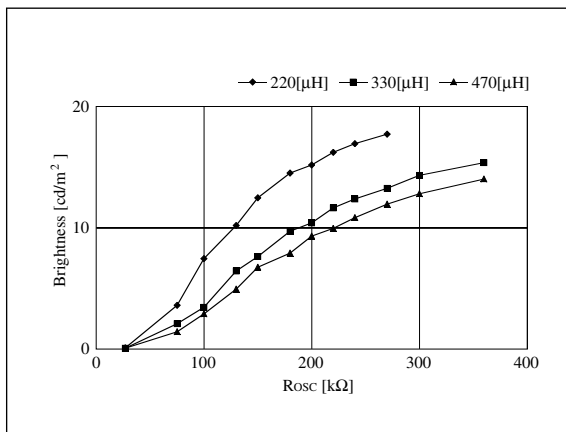

Figure 36. R_{OSC} – Brightness

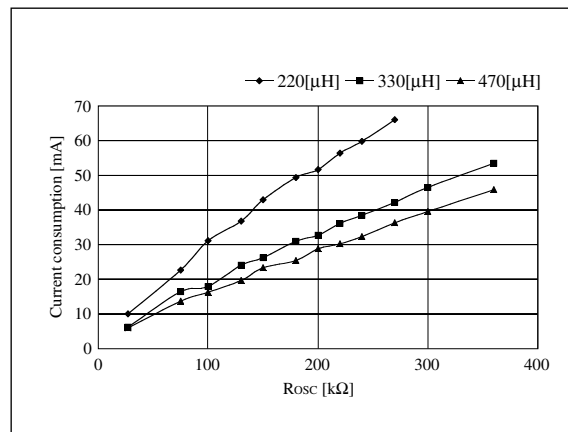

Figure 37. R_{OSC} – Current consumption

V_{DD}: 5.0 [V], EL size: 50 [cm²], inductor: Toko D73LCE-817CE

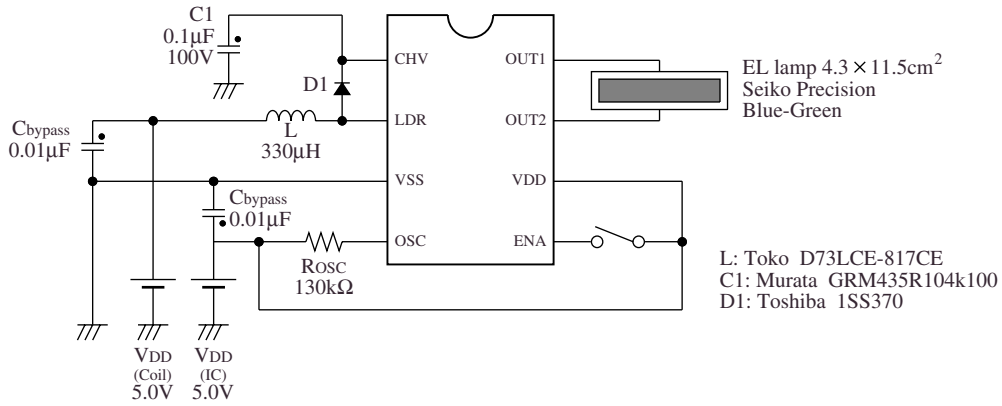

Figure 38. Application circuit

EL size [cm ²]	Inductance [µH]	R _{OSC} [kΩ]	Current consumption [mA]	f _{OUT} [Hz]	V _{OUT} [Vp-p]	Brightness [cd/m ²]
49.5	470	160	41.8	280	180	23.5
49.5	470	91	26.9	478	121	13.5
49.5	330	130	53.7	342	181	27.6
49.5	330	68	33.9	620	118	14.4
49.5	220	91	54.3	477	158	26.3
49.5	220	51	36.4	808	109	13.2

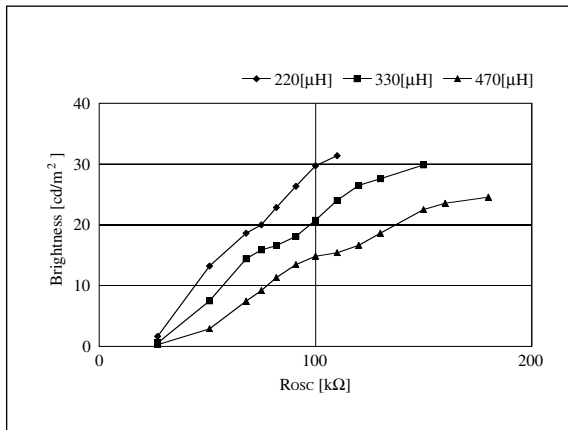

Figure 39. R_{OSC} – Brightness

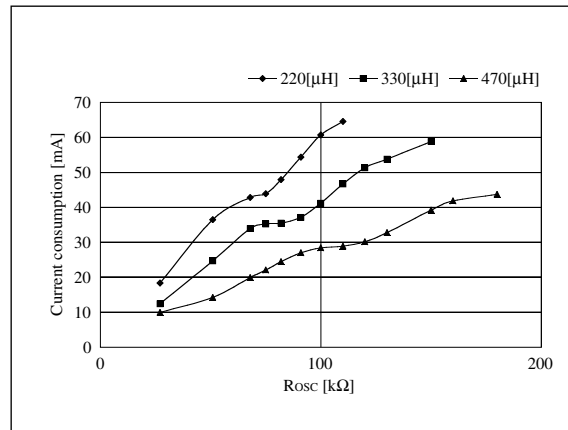

Figure 40. R_{OSC} – Current consumption

V_{DD}: 5.0 [V], EL size: 50 [cm²], inductor: Panasonic ELL6SH

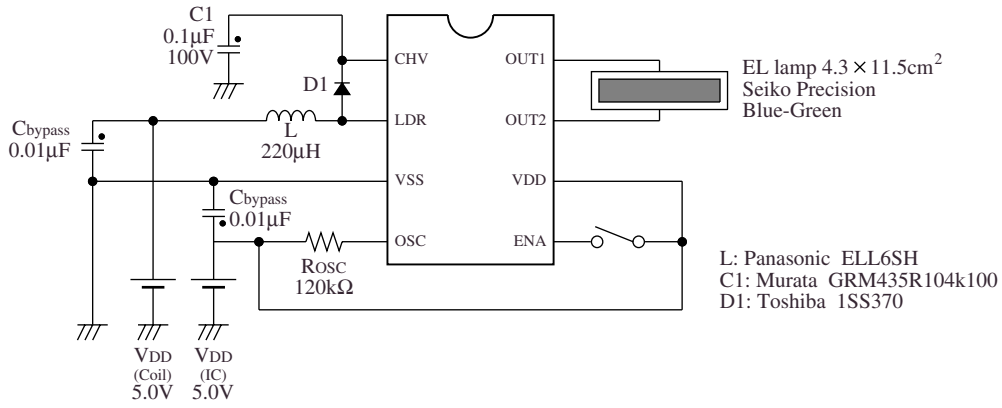

Figure 41. Application circuit

EL size [cm ²]	Inductance [µH]	R _{OSC} [kΩ]	Current consumption [mA]	f _{OUT} [Hz]	V _{OUT} [Vp-p]	Brightness [cd/m ²]
49.5	470	180	41.4	253	184	22.6
49.5	470	110	27.1	400	126	13.6
49.5	330	160	44.7	281	184	23.8
49.5	330	100	29.3	439	124	14.2
49.5	220	120	55.7	369	176	26.7
49.5	220	68	36.2	619	118	14.6

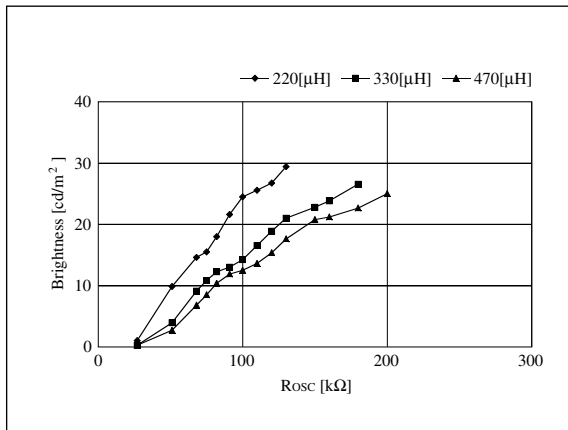

Figure 42. R_{OSC} – Brightness

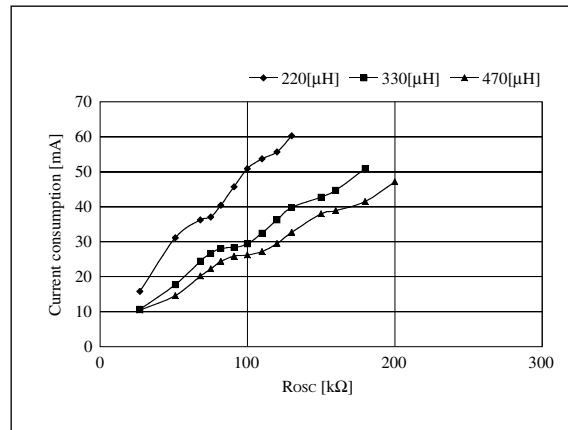

Figure 43. R_{OSC} – Current consumption

CONSIDERATIONS SEVERAL TYPES of NOISE

This section considers several types of noise subdivided into audible noise, electromagnetic noise, and

supply wraparound noise. Please refer to datasheet for details.

Audible Noise

Audible noises (or ringing) are mainly caused by the capacitor (C_{CHV}) and the EL panel itself. In addition to the noise from these sources is resonant noise

from the case, PCB and other components (especially the capacitor).

Capacitor (C_{CHV})

Electrical Considerations

The capacitor (C_{CHV}) connection is very susceptible to ringing noise generation due to voltage fluctuations caused by the EL driver. Generally speaking, high-withstand voltage type capacitors generate less ringing noise.

Relatively high ringing output ceramic chip capacitors can be replaced with low ringing output mylar chip capacitors, and further benefit can be obtained if mounting and cost aspects allow.

If the range of devices available for selection is small, electrically reducing the effect of voltage fluctuations will reduce the ringing noise generated. Specifically, R_{CHV} should be inserted (10 to 20k Ω) and R_{OUT} should be increased (50k Ω max).

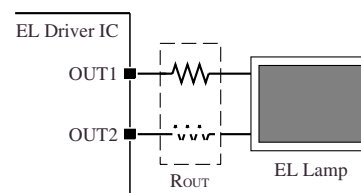
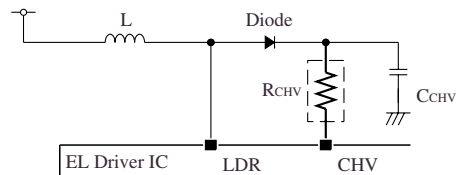

The reduction in C_{CHV} ringing noise is the same in both cases, but making R_{OUT} larger does have an unfavorable result on efficiency. Inserting R_{CHV} , however, is an effective way of reducing only the C_{CHV} ringing noise.

Physical Considerations

The capacitor, which generates the ringing noise, should be mounted as close as possible to the support struts to reduce PCB and case resonant noise. If possible, a more sturdy PCB construction should also be considered.

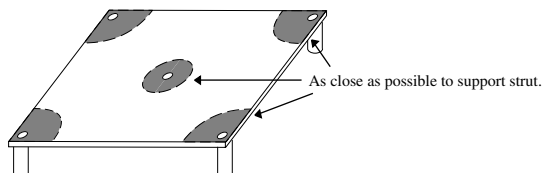

Furthermore, if the chip capacitor is mounted laying on its side, then the contact area with the PCB is minimized which will also help reduce noise.

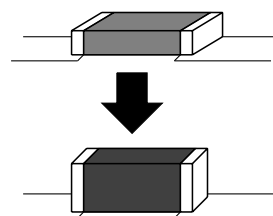

EL Lamp

The EL display has a piezoelectric characteristic, which may generate output noise. There is generally 2 sources that can cause noise, the potential differ-

Electrical Considerations

The EL lamp noise can be reduced by inserting R_{OUT} ($50k\Omega$ max) which causes the output waveform to be modified such that the high-frequency components are reduced (see page 4, Output Waveform).

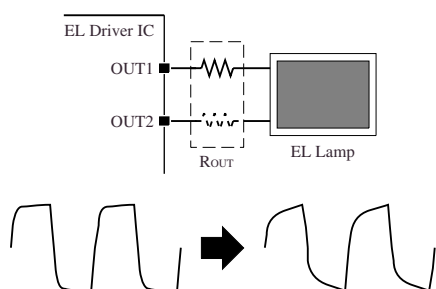

A shielded (3-pin type) EL display is effective in preventing noise between the EL display and other components. Also, the piezoelectric effect can be prevented by avoiding potentials on plane surfaces, such as VDD or ground planes.

Electromagnetic Noise

In addition to the EL lamp acting as an antenna, the driver circuit with its high-voltage booster circuit that uses an inductor and capacitor generates radi-

Wiring and Layout

In particular, all circuit wiring between the high-voltage inductor, capacitor (C_{CHV}), diode and EL driver LDR pin should be as thick and as short as possible.

EL Lamp

The EL lamp can act as an antenna and emit noise, so, where possible, a shielded EL lamp should be used to reduce the emitted noise.

Components easily affected by induced noise should have their wiring located well away from the EL lamp wiring to prevent induced noise.

Resistor R_{OUT} can be inserted to reduce the high-frequency component of the EL driver waveform.

Inductor

The inductor is a source of electromagnetic noise, so peripheral components should have high impedance and wiring layout to avoid induced noise. If possible,

ence between the EL display electrodes and the potential difference between the EL display and other components, such as a ground plane.

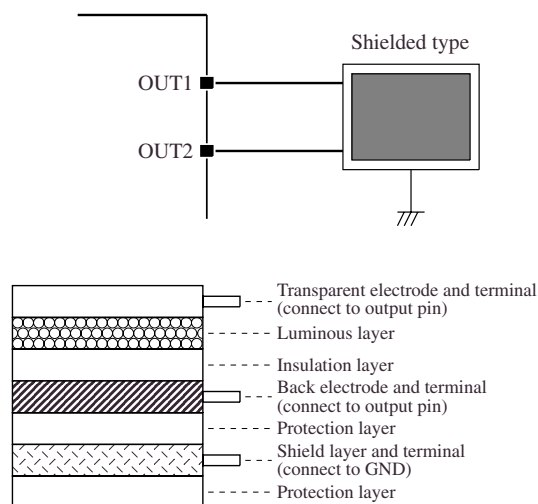

Construction of shielded EL

Physical Considerations

The most effective means of protecting the EL display physically is by using non-woven fabric cloth or PET (plastic) film for absorbing and limiting vibration.

ated noise caused by the current and capacitive noise induced by the voltage.

Also, the wiring between the outputs (OUT1, OUT2) and EL lamp should be as thick and as short as possible.

Resistors can be inserted at one or both outputs to the EL lamp. If a single resistor is inserted, it can be inserted in the output closest to components affected by induced noise, or in the output furthest from components affected by induced noise. Generally, it is not possible to definitively say which method is the most effective. The best result is obtained by trial-and-error.

the inductor should be a closed-magnetic type, such as a toroid.

Supply Wraparound Noise

In the booster circuit, the inductor drive transistor switches ON/OFF, generating a sawtooth waveform (see page 3, Figure 8) whose pulse travels from the EL driver LDR pin through to the VSS pin, thereby forming a return path back to the supply. Accordingly, a bypass capacitor (C_{Bypass}) should be connected, adjacent to the inductor, between the

inductor and the EL driver VSS pin to absorb the pulses.

Note that the LDR pin voltage is boosted by the inductor and can have amplitudes up to 100V.

The supply system connected to the inductor should also be separated as much as possible from the supply lines for other components.

Notice to Application Circuit

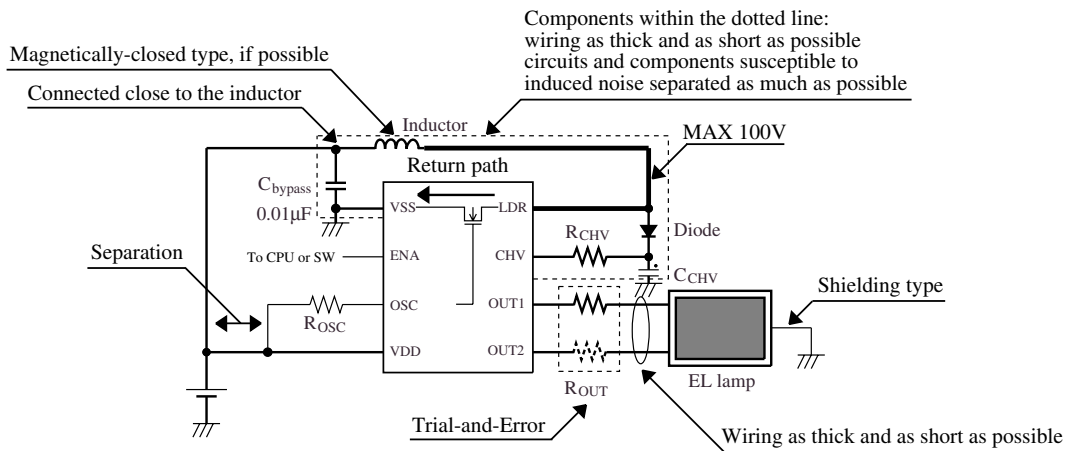

Component	Description	Value
Inductor	Booster inductor. The current flowing through the inductor is a triangular waveform, and care should be taken so that the peak current does not exceed the maximum current. An inductor with low resistance will help reduce loss.	0.15 to 0.68mH
Diode	A fast recovery diode with short reverse recovery time at peak reverse voltages exceeding 100V.	
C_{CHV}	Capacitor rated at $\geq 100V$	0.1 μ F (100V)
R_{OSC}	inductor and EL drive frequency control resistor	51 to 1000k Ω
C_{Bypass}	Supply bypass capacitor (noise cut)	0.01 μ F
R_{CHV}	Optional. Reduces the output waveform rise time, and reduces noise.	10 to 20k Ω
R_{OUT}	Optional. Reduces noise emitted by the EL element.	$\leq 50k\Omega$

EQUIVALENT CIRCUIT

The EL display driver must not be operated without an output load as this may damage the IC. For testing purposes, including testing during the manufacturing process, where the IC cannot be connected to an EL display, the following equivalent circuit should be used.

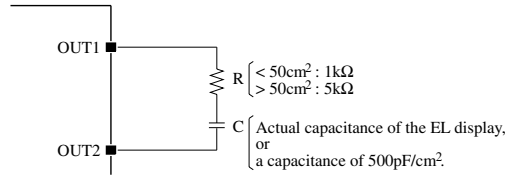

FOOTPRINT

The optimum footprint varies depending on the board material, soldering paste, soldering method, and equipment accuracy, all of which need to be considered to meet design specifications.

(Unit: mm)

Package	b2	L2	e	e1
VSOP-8	0.55	0.95	0.65	5.90

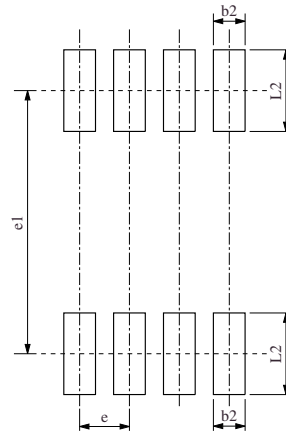

NIPPON PRECISION CIRCUITS INC. reserves the right to make changes to the products described in this document in order to improve the design or performance and to supply the best possible products. Nippon Precision Circuits Inc. assumes no responsibility for the use of any circuits shown in this document, conveys no license under any patent or other rights, and makes no claim that the circuits are free from patent infringement. Applications for any devices shown in this document are for illustration only and Nippon Precision Circuits Inc. makes no claim or warranty that such applications will be suitable for the use specified without further testing or modification. The products described in this document are not intended to use for the apparatus which influence human lives due to the failure or malfunction of the products. Customers are requested to comply with applicable laws and regulations in effect now and hereinafter, including compliance with export controls on the distribution or dissemination of the products. Customers shall not export, directly or indirectly, any products without first obtaining required licenses and approvals from appropriate government agencies.



NIPPON PRECISION CIRCUITS INC.

4-3, Fukuzumi 2-chome, Koto-ku,
Tokyo 135-8430, Japan
Telephone: +81-3-3642-6661
Facsimile: +81-3-3642-6698
<http://www.npc.co.jp/>
Email: sales@npc.co.jp

NK0005BE 2001.12